



# DTC50

COMPACT PILING RIG



# DTC

## COMPACT PILING RIGS

The DTC series was designed in 2006 in order to satisfy the growing market of compact piling rigs which stand out in maneuverability, ease of transport, low maintenance and running costs.

The DTC design choices ensure an overall lighter structure (at equivalent robustness) than usual machines, which permit the assembly on medium-small size base excavators.

Its compact size guarantees a superior agility in the jobsites, which results in high productivity comparable with much larger piling rigs.

The innovative architecture consists of a steel boom which support a monolithic mast capable of independent vertical translation. The new concept of a boxed steel mast, which internally contains the telescopic Kelly bar, allowing for a higher rigidity, better stability (the Kelly bar is closer to the crawler base compared to an external Kelly configuration), and a reduction of noise during

the tool discharge. Other unique features include the possibility of a wide range of mast positions, with longer reach compared to a traditional machine, along with better visibility of the working area. The winches, mounted directly on the mast, make the rope movements independent from the mast positioning, improving the easiness of operation and cables' durability.

## Electronic devices

DTC series machines are equipped with an electronic system which controls and displays several functions and parameters.

- Automatic alignment of the mast
- Mast inclination display
- Depth measuring device

A GPS system enables GEAX owners to monitor and manage their machines remotely by a PC connected to the Internet



# DTC

## COMPACT PILING RIGS

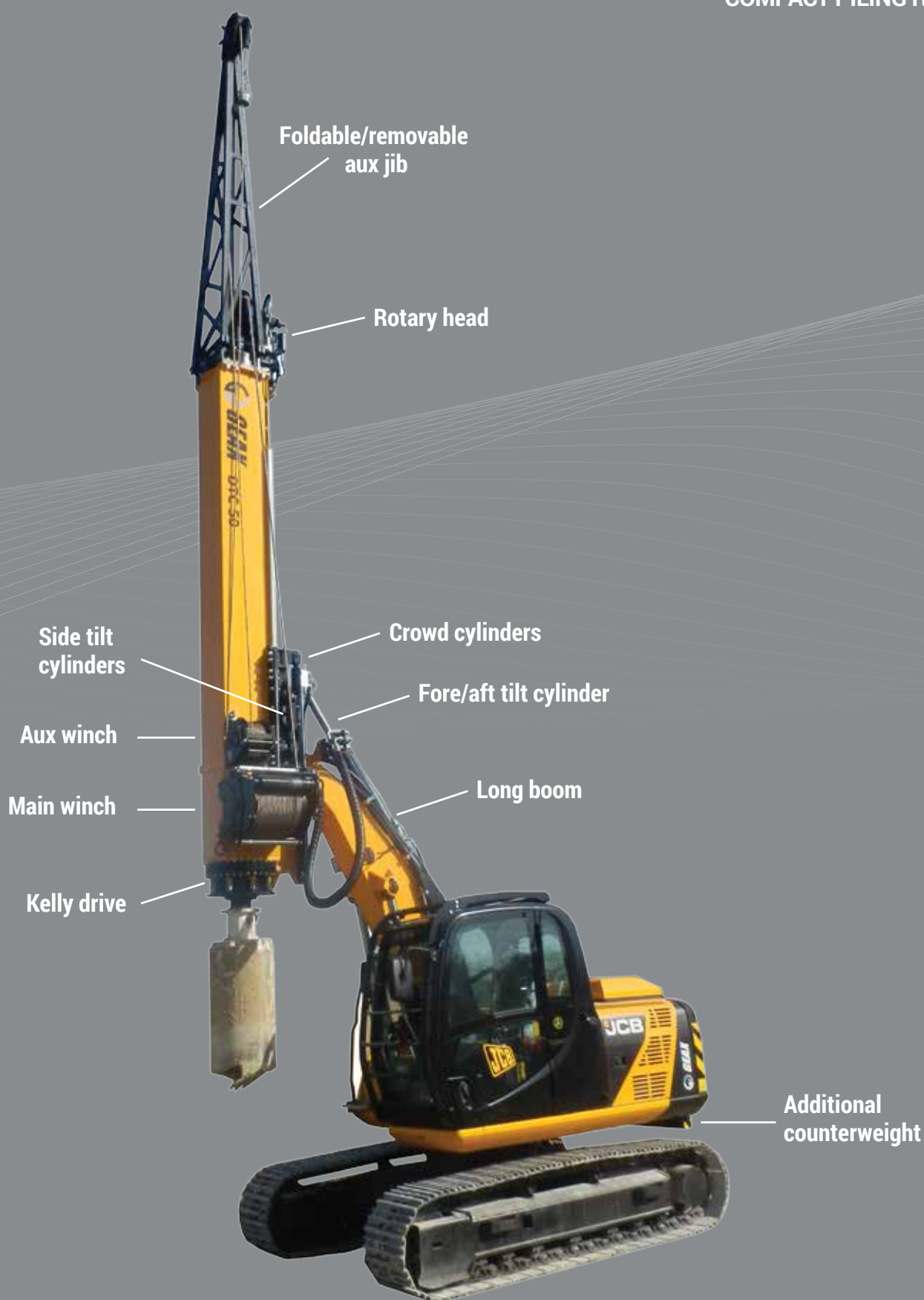

# DTC50

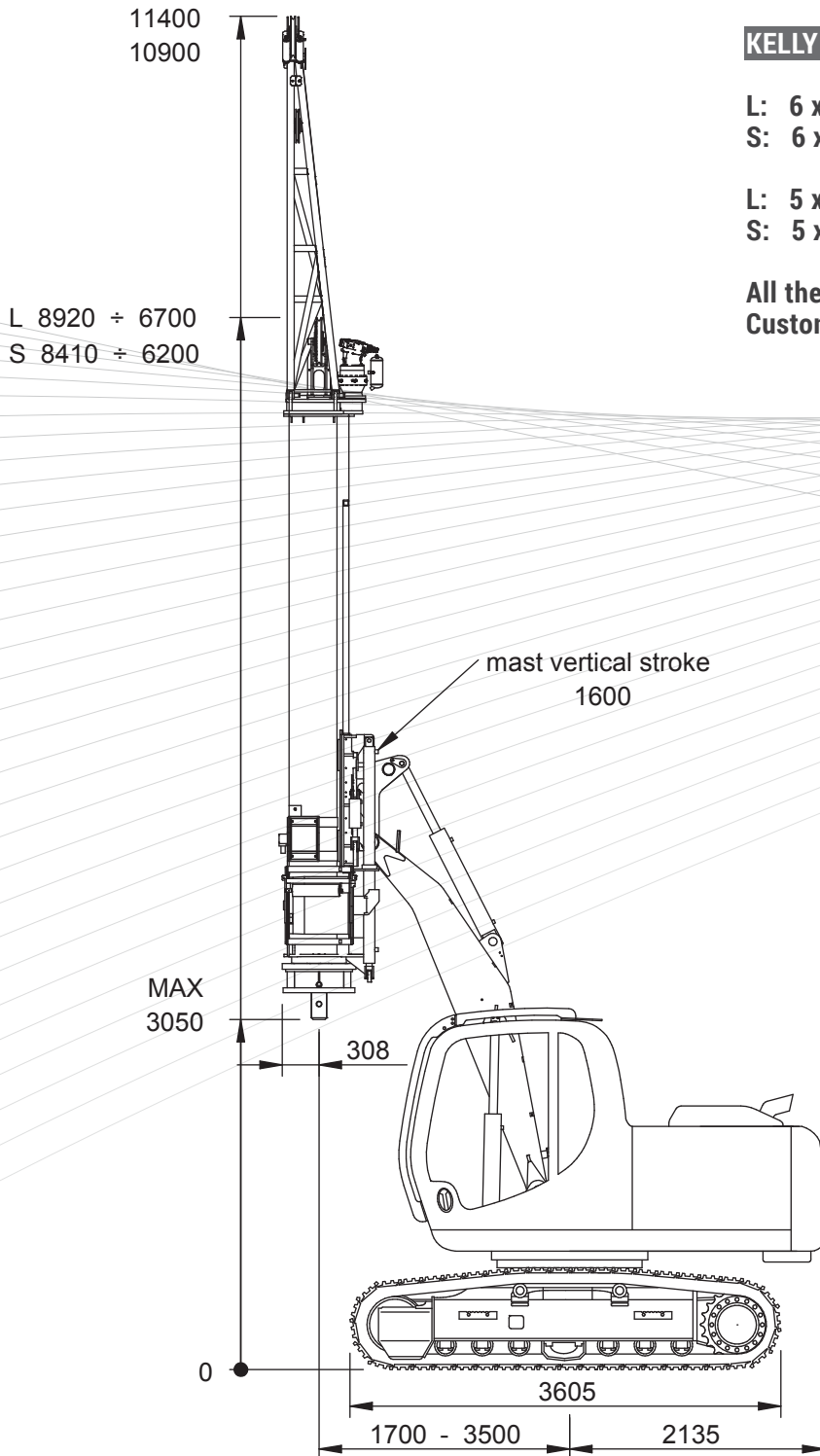

## KELLY BAR OPTIONS

	Depth
L: 6 x 4.6 m Standard	25 m
S: 6 x 4 m Standard	21 m
L: 5 x 4.6 m Heavy Duty	21 m
S: 5 x 4 m Heavy Duty	17.5 m

All the kelly bars are round interlocking  
Custom measures available upon request

# DTC50

BASE		HITACHI ZX130 / JCB JS130
Engine	<i>type</i>	ISUZU AM-4JJ1X / JCB ECOmax 444
Engine power	<i>kW (hp)</i>	73.4 (98) / 81 (109)
Undercarriage length	<i>mm - ft</i>	3580 - 11.75 / 3605 - 11.82
Width over tracks	<i>mm - ft</i>	2490 - 8.2
Shoe width	<i>mm - in</i>	500 - 19.7
HYDRAULIC SYSTEM		
Main pumps	<i>l/min</i>	2x117 / 2x124
Auxiliary pump	<i>l/min</i>	2x33.6 / 2x20.5
Hydraulic pressure	<i>bar</i>	320
MAST		
Forward inclination	<i>deg</i>	20
Backward inclination	<i>deg</i>	20
Lateral inclination	<i>deg</i>	6.5
Mast vertical stroke	<i>mm - ft</i>	1600 - 5.25
ROTARY		
Nominal torque	<i>kNm - lbf ft</i>	47 - 34.700
Drilling speed	<i>rpm</i>	10 ÷ 60
Spin off speed	<i>rpm</i>	60
WINCHES		
Main winch line pull	<i>kN - lbf</i>	80 - 18.000
Aux winch line pull	<i>kN - lbf</i>	25 - 5.600
CROWD SYSTEM		
Pull down force	<i>kN - lbf</i>	80 - 18.000
Extraction force	<i>kN - lbf</i>	180 - 40.450
EXCAVATION		
Max pile diameter	<i>mm - in</i>	1.200 - 48
Max pile depth	<i>m - ft</i>	up tp 25 - 82
Min working height	<i>mm - ft</i>	6.200 - 20.3
TRANSPORT		
Length	<i>mm - ft</i>	8.600 - 28.2
Width	<i>mm - ft</i>	2.490 - 8.2
Height	<i>mm - ft</i>	3.050 - 10
Weight	<i>kg - lbs</i>	17.000 - 37.500

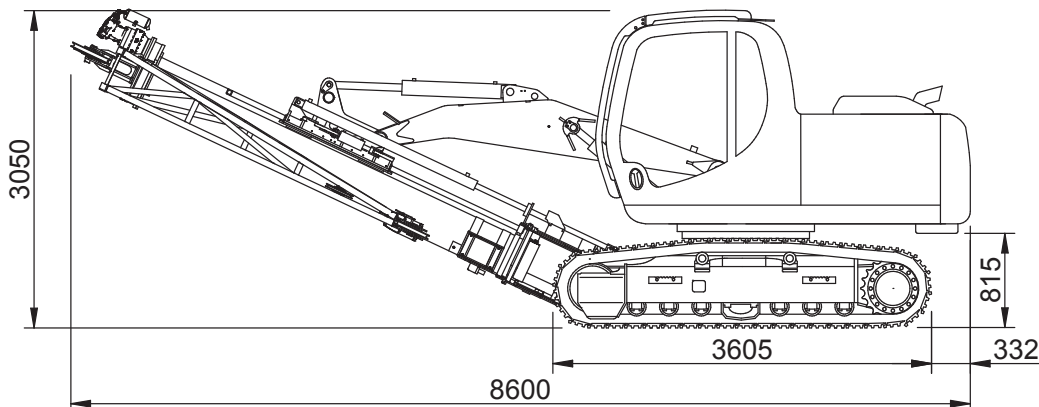



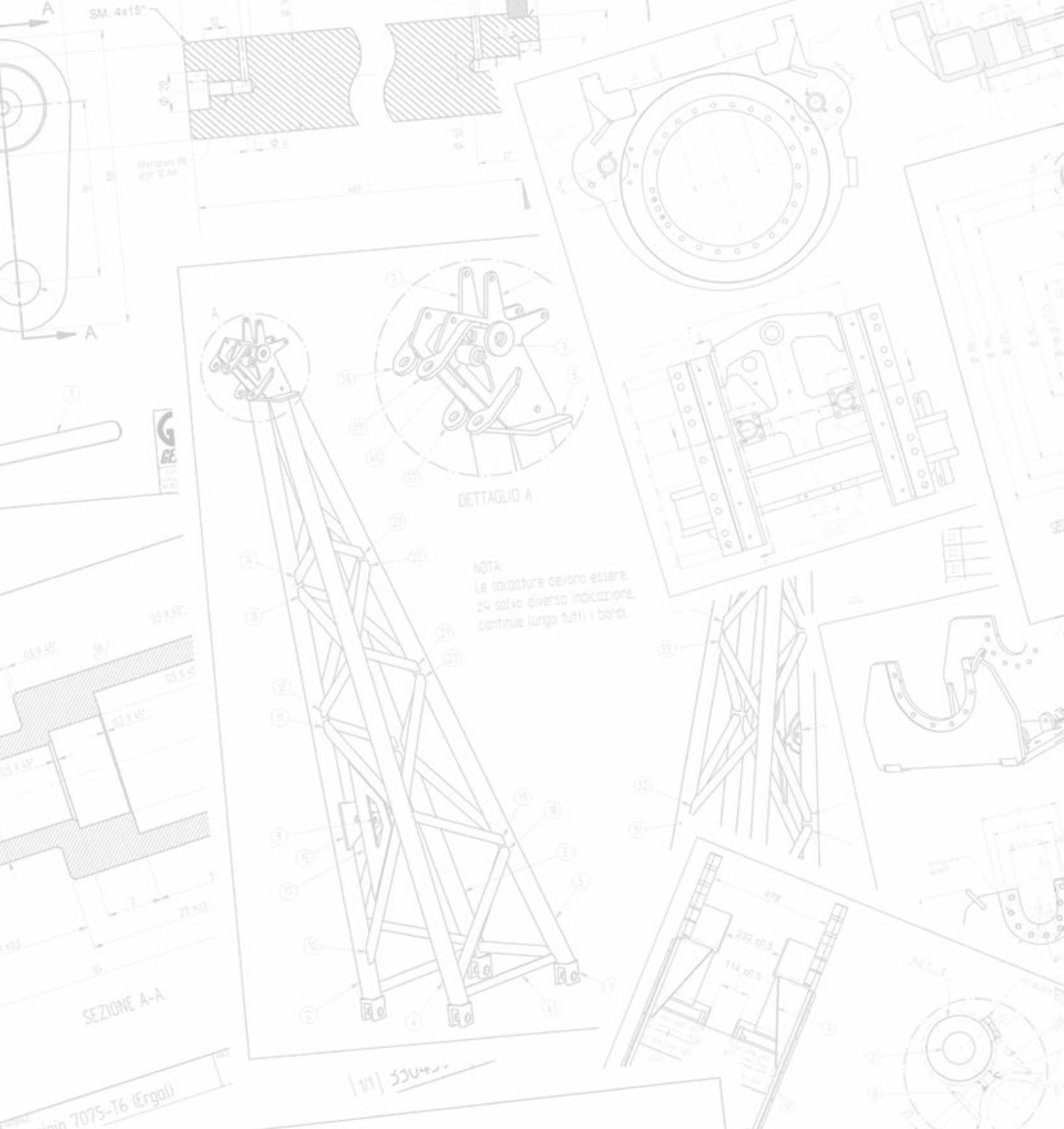

DETTAGLIO A

NOTA:  
Le saldature devono essere  
24 salvo diversa indicazione  
continue lungo tutti i bordi.

SEZIONE A-A

SEZIONE A-A



Via Campoceraso 13 - 60027 OSIMO (AN) ITALY

Tel: +39 0717131953 - Fax: +39 071715199  
geax.it - info@geax.it





